

ENGINEER/SURVEYOR:
CIVIL DESIGN ADVANTAGE
3405 SE CROSSROADS DR, SUITE G
GRIMES, IOWA 50111

OWNER/DEVELOPER:
DIAMOND DEVELOPMENT, LLC
309 E. 1ST STREET
ANKENY, IOWA 50021

LOST LAKE ESTATES PLAT 2

FINAL PLAT

CITY CLERK APPROVAL



NOTE

- 4'-WIDE SIDEWALKS SHALL BE CONSTRUCTED ON BOTH SIDES OF ALL STREETS WITHIN PUBLIC RIGHT-OF-WAY, IN CONJUNCTION WITH THE BUILDING PERMIT. LOT 1 SHALL BE REQUIRED TO CONSTRUCT A 4'-WIDE SIDEWALK ALONG N. BROADWAY STREET IN CONJUNCTION WITH THE BUILDING PERMIT. SIDEWALK RAMPS DAMAGED DURING HOME CONSTRUCTION SHALL BE REPAIRED IN CONJUNCTION WITH THE BUILDING PERMIT. (IT IS NOT THE CITY'S RESPONSIBILITY TO DETERMINE SIDEWALK ELEVATIONS; THE BUILDER IS REQUIRED TO CONSTRUCT THEM IN ACCORDANCE WITH ADA REQUIREMENTS.)
- ANY ELEVATIONS SHOWN ON THE FINAL PLAT WERE PROVIDED BY PROJECT ENGINEER AND ARE NOT CERTIFIED BY THIS SURVEYOR.
- LOT 1 AND OUTLOT 'Z' SHALL NOT BE PERMITTED DRIVEWAY ACCESS TO N. BROADWAY STREET.
- THERE SHALL BE ONLY ONE DRIVEWAY PERMITTED FOR LOTS 1-29.
- NO ROOF DRAINS OR SUBDRAINS SHALL BE EXTENDED INTO THE 35' BUFFER EASEMENT OR INTO THE 35' REAR YARD ON LOTS 2-8, ADJACENT TO OUTLOT 'Z' OF LOST LAKES ESTATES PLAT 1.
- THE BUILDING PERMIT FOR LOT 3 SHALL REQUIRE THE APPROVAL BY THE PUBLIC WORKS DIRECTOR. THE HOMEOWNER WILL BE REQUIRED TO GRIND THE CURB AND INSTALL AN ADA ACCESSIBLE SIDEWALK RAMP WITH GRAY DETECTABLE WARNINGS AT THE CROSSWALK ACROSS LOST LAKE DRIVE WHICH CONNECT TO THE SIDEWALKS WEST OF LOST LAKES DRIVE, SOUTH OF MEADOW LARK DRIVE, UNLESS THE PUBLIC WORKS DIRECTOR DETERMINES THE ACTUAL LOT 3 DRIVEWAY IS AN ACCEPTABLE ALTERNATIVE TO SAID RAMP.
- THE ADJACENT PROPERTY OWNER SHALL BE RESPONSIBLE FOR SNOW REMOVAL AND SIDEWALK REPAIR AT EACH CLUSTER MAILBOX.
- ANY TREES PLANTED WITHIN LOTS 9-11 SHALL BE MAINTAINED BY THE PROPERTY OWNER.
- NO LOTS WITHIN LOST LAKE ESTATES PLAT 2 SHALL BE PERMITTED TO HAVE AN INDIVIDUAL MAILBOX.
- FOUNDATIONS FOR DWELLINGS ON LOTS 20-21 AND LOTS 24-28 SHALL BE DESIGNED AND CERTIFIED BY A GEOTECHNICAL OR STRUCTURAL ENGINEER PRIOR TO ISSUANCE OF A BUILDING PERMIT FOR SAID LOTS.
- THE PROPERTY OWNER SHALL BE RESPONSIBLE FOR MAINTENANCE OF ALL EMBANKMENTS INCLUDING REPAIR OF ANY DAMAGE DUE TO EROSION, WITHIN ALL OVERLAND FLOWAGE EASEMENTS OR REAR YARDS.
- THE CITY SHALL HAVE THE RIGHT, BUT NOT THE OBLIGATION, TO REMOVE DRAINAGE OBSTRUCTIONS FROM THE OVERLAND FLOWAGE EASEMENT AREAS.

PLAT DESCRIPTION:

A PART OF PARCEL 'D' AS SHOWN ON THE PLAT OF SURVEY RECORDED IN BOOK 14526, PAGE 302-303 BEING A PART OF LOTS 21, 22 AND 23, IN THE OFFICIAL PLAT OF SECTION 35, TOWNSHIP 81 NORTH, RANGE 25 WEST OF THE FIFTH PRINCIPAL MERIDIAN, IN THE CITY OF POLK CITY, POLK COUNTY, IOWA MORE PARTICULARLY DESCRIBED AS FOLLOWS:

BEGINNING AT THE NORTHWEST CORNER OF LOT 29, LOST LAKE ESTATES PLAT 1, AN OFFICIAL PLAT; THENCE NORTH 00°18'59" WEST ALONG THE WEST LINE OF SAID PARCEL 'D', 618.91 FEET TO THE NORTHWEST CORNER OF SAID PARCEL 'D'; THENCE SOUTH 89°48'49" EAST ALONG THE NORTH LINE OF SAID PARCEL 'D', 764.56 FEET; THENCE SOUTH 00°11'11" WEST ALONG SAID NORTH LINE, 8.95 FEET; THENCE SOUTH 89°48'49" EAST ALONG SAID NORTH LINE, 216.10 FEET TO THE NORTHEAST CORNER OF SAID PARCEL 'D'; THENCE SOUTHERLY ALONG A CURVE CONCAVE EASTERLY WHOSE RADIUS IS 851.51 FEET, WHOSE ARC LENGTH IS 22.16 FEET AND WHOSE CHORD BEARS SOUTH 07°25'23" EAST, 22.16 FEET TO THE NORTHERLY LINE OF SAID LOST LAKE ESTATES PLAT 1; THENCE NORTH 89°48'49" WEST ALONG SAID NORTHERLY LINE, 7.07 FEET; THENCE SOUTHERLY ALONG SAID NORTHERLY LINE AND A CURVE CONCAVE EASTERLY WHOSE RADIUS IS 858.51 FEET, WHOSE ARC LENGTH IS 81.53 FEET AND WHOSE CHORD BEARS SOUTH 10°49'14" EAST, 81.50 FEET TO THE NORTHEAST CORNER OF OUTLOT 'Z', LOST LAKE ESTATES PLAT 1; THENCE SOUTH 12°32'28" WEST ALONG THE NORTHERLY LINE OF SAID LOST LAKE ESTATES PLAT 1, A DISTANCE OF 81.90 FEET; THENCE SOUTH 05°52'14" WEST ALONG SAID NORTHERLY LINE, 90.53 FEET; THENCE SOUTH 01°40'49" WEST ALONG SAID NORTHERLY LINE, 80.16 FEET; THENCE SOUTH 04°54'36" WEST ALONG SAID NORTHERLY LINE, 75.40 FEET; THENCE SOUTH 00°22'24" EAST ALONG SAID NORTHERLY LINE, 67.03 FEET; THENCE SOUTH 05°23'04" EAST ALONG SAID NORTHERLY LINE, 65.25 FEET; THENCE SOUTH 80°00'00" WEST ALONG SAID NORTHERLY LINE, 149.14 FEET; THENCE SOUTH 89°48'49" WEST ALONG SAID NORTHERLY LINE, 149.14 FEET; THENCE SOUTH 80°00'00" WEST ALONG SAID NORTHERLY LINE, 149.14 FEET; THENCE SOUTH 09°19'41" EAST ALONG SAID NORTHERLY LINE, 70.98 FEET TO THE NORTHEAST CORNER OF LOT 39, LOST LAKE ESTATES PLAT 1; THENCE SOUTH 75°48'07" WEST ALONG SAID NORTHERLY LINE, 145.00 FEET TO THE NORTHWEST CORNER OF LOT 39, LOST LAKE ESTATES PLAT 1; THENCE NORTH 14°11'53" WEST ALONG SAID NORTHERLY LINE, 3.87 FEET; THENCE SOUTH 75°48'07" WEST ALONG SAID NORTHERLY LINE, 199.95 FEET TO THE NORTHWEST CORNER OF LOT 38, LOST LAKE ESTATES PLAT 1; THENCE SOUTH 85°06'34" WEST ALONG SAID NORTHERLY LINE, 81.06 FEET TO THE NORTHWEST CORNER OF LOT 36, LOST LAKE ESTATES PLAT 1; THENCE SOUTH 81°47'12" WEST ALONG SAID NORTHERLY LINE, 42.15 FEET TO THE NORTHWEST CORNER OF LOT 35, LOST LAKE ESTATES PLAT 1; THENCE NORTH 78°05'03" WEST ALONG SAID NORTHERLY LINE, 37.73 FEET TO THE NORTHWEST CORNER OF LOT 34, LOST LAKE ESTATES PLAT 1; THENCE NORTH 58°18'17" WEST ALONG SAID NORTHERLY LINE, 37.84 FEET; THENCE NORTH 38°47'24" WEST ALONG SAID NORTHERLY LINE, 36.73 FEET; THENCE NORTH 19°35'09" WEST ALONG SAID NORTHERLY LINE, 36.66 FEET; THENCE NORTH 01°46'41" WEST ALONG SAID NORTHERLY LINE, 61.36 FEET TO THE NORTHEAST CORNER OF LOT 30, LOST LAKE ESTATES PLAT 1; THENCE SOUTH 89°41'01" WEST ALONG SAID NORTHERLY LINE, 260.00 FEET; THENCE SOUTH 00°18'59" EAST ALONG SAID NORTHERLY LINE, 16.02 FEET TO THE NORTHEAST CORNER OF LOT 29, LOST LAKE ESTATES PLAT 1; THENCE SOUTH 89°41'01" WEST ALONG SAID NORTHERLY LINE, 150.00 FEET TO THE POINT OF BEGINNING AND CONTAINING 14.72 ACRES (641,268 SQUARE FEET) THE PROPERTY IS SUBJECT TO ANY AND ALL EASEMENTS OF RECORD.

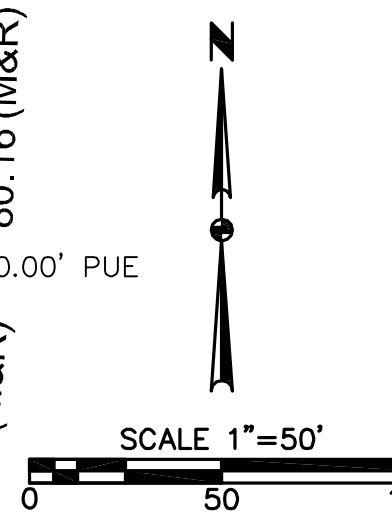

BULK REGULATIONS:

MINIMUM LOT AREA: 9,400 SF
MINIMUM LOT WIDTH: 80 FEET
SETBACKS:
FRONT: 30 FEET
REAR: 35 FEET
SPECIAL SETBACK FOR LOTS 21, 23-24: 8 FEET
SIDE: 30 FEET

ZONING:

R-1AR RESTRICTED TO:
1. MINIMUM 80' LOT WIDTH
2. MINIMUM REAR YARD SETBACK = 35'
3. MINIMUM LOT AREA = 9400 SF

CURVE DATA:

CURVE	DELTA	RADIUS	LENGTH	BEARING	CHORD	C10	C11	C12	C13	C14	C15	C16	C17	C18	C19	C20	C21	C22	C23	C24	C25	C26	C27	C28	C29	C30	C31	C32	C33	C34	C35	C36	C37	C38	C39																																																																																																																																																																																																																																																																																																																																																																																																																																																																																																																																																																																																																																																																																																																					
C1	1°29'27"	851.51'	22.16'	S7°25'23"E	22.16'	770.00'	47.45'	S12°25'58"E	47.44'	770.00'	83.18'	S6°14'00"E	83.14'	770.00'	83.28'	S0°02'24"E	83.24'	770.00'	83.18'	S6°14'00"E	83.14'	770.00'	47.45'	S12°25'58"E	47.44'	770.00'	83.18'	S6°14'00"E	83.14'	770.00'	83.28'	S0°02'24"E	83.24'	770.00'	83.18'	S6°14'00"E	83.14'	770.00'	47.45'	S12°25'58"E	47.44'	770.00'	83.18'	S6°14'00"E	83.14'	770.00'	83.28'	S0°02'24"E	83.24'	770.00'	83.18'	S6°14'00"E	83.14'	770.00'	47.45'	S12°25'58"E	47.44'	770.00'	83.18'	S6°14'00"E	83.14'	770.00'	83.28'	S0°02'24"E	83.24'	770.00'	83.18'	S6°14'00"E	83.14'	770.00'	47.45'	S12°25'58"E	47.44'	770.00'	83.18'	S6°14'00"E	83.14'	770.00'	83.28'	S0°02'24"E	83.24'	770.00'	83.18'	S6°14'00"E	83.14'	770.00'	47.45'	S12°25'58"E	47.44'	770.00'	83.18'	S6°14'00"E	83.14'	770.00'	83.28'	S0°02'24"E	83.24'	770.00'	83.18'	S6°14'00"E	83.14'	770.00'	47.45'	S12°25'58"E	47.44'	770.00'	83.18'	S6°14'00"E	83.14'	770.00'	83.28'	S0°02'24"E	83.24'	770.00'	83.18'	S6°14'00"E	83.14'	770.00'	47.45'	S12°25'58"E	47.44'	770.00'	83.18'	S6°14'00"E	83.14'	770.00'	83.28'	S0°02'24"E	83.24'	770.00'	83.18'	S6°14'00"E	83.14'	770.00'	47.45'	S12°25'58"E	47.44'	770.00'	83.18'	S6°14'00"E	83.14'	770.00'	83.28'	S0°02'24"E	83.24'	770.00'	83.18'	S6°14'00"E	83.14'	770.00'	47.45'	S12°25'58"E	47.44'	770.00'	83.18'	S6°14'00"E	83.14'	770.00'	83.28'	S0°02'24"E	83.24'	770.00'	83.18'	S6°14'00"E	83.14'	770.00'	47.45'	S12°25'58"E	47.44'	770.00'	83.18'	S6°14'00"E	83.14'	770.00'	83.28'	S0°02'24"E	83.24'	770.00'	83.18'	S6°14'00"E	83.14'	770.00'	47.45'	S12°25'58"E	47.44'	770.00'	83.18'	S6°14'00"E	83.14'	770.00'	83.28'	S0°02'24"E	83.24'	770.00'	83.18'	S6°14'00"E	83.14'	770.00'	47.45'	S12°25'58"E	47.44'	770.00'	83.18'	S6°14'00"E	83.14'	770.00'	83.28'	S0°02'24"E	83.24'	770.00'	83.18'	S6°14'00"E	83.14'	770.00'	47.45'	S12°25'58"E	47.44'	770.00'	83.18'	S6°14'00"E	83.14'	770.00'	83.28'	S0°02'24"E	83.24'	770.00'	83.18'	S6°14'00"E	83.14'	770.00'	47.45'	S12°25'58"E	47.44'	770.00'	83.18'	S6°14'00"E	83.14'	770.00'	83.28'	S0°02'24"E	83.24'	770.00'	83.18'	S6°14'00"E	83.14'	770.00'	47.45'	S12°25'58"E	47.44'	770.00'	83.18'	S6°14'00"E	83.14'	770.00'	83.28'	S0°02'24"E	83.24'	770.00'	83.18'	S6°14'00"E	83.14'	770.00'	47.45'	S12°25'58"E	47.44'	770.00'	83.18'	S6°14'00"E	83.14'	770.00'	83.28'	S0°02'24"E	83.24'	770.00'	83.18'	S6°14'00"E	83.14'	770.00'	47.45'	S12°25'58"E	47.44'	770.00'	83.18'	S6°14'00"E	83.14'	770.00'	83.28'	S0°02'24"E	83.24'	770.00'	83.18'	S6°14'00"E	83.14'	770.00'	47.45'	S12°25'58"E	47.44'	770.00'	83.18'	S6°14'00"E	83.14'	770.00'	83.28'	S0°02'24"E	83.24'	770.00'	83.18'	S6°14'00"E	83.14'	770.00'	47.45'	S12°25'58"E	47.44'	770.00'	83.18'	S6°14'00"E	83.14'	770.00'	83.28'	S0°02'24"E	83.24'	770.00'	83.18'	S6°14'00"E	83.14'	770.00'	47.45'	S12°25'58"E	47.44'	770.00'	83.18'	S6°14'00"E	83.14'	770.00'	83.28'	S0°02'24"E	83.24'	770.00'	83.18'	S6°14'00"E	83.14'	770.00'	47.45'	S12°25'58"E	47.44'	770.00'	83.18'	S6°14'00"E	83.14'	770.00'	83.28'	S0°02'24"E	83.24'	770.00'	83.18'	S6°14'00"E	83.14'	770.00'	47.45'	S12°25'58"E	47.44'	770.00'	83.18'	S6°14'00"E	83.14'	770.00'	83.28'	S0°02'24"E	83.24'	770.00'	83.18'	S6°14'00"E	83.14'	770.00'	47.45'	S12°25'58"E	47.44'	770.00'	83.18'	S6°14'00"E	83.14'	770.00'	83.28'	S0°02'24"E	83.24'	770.00'	83.18'	S6°14'00"E	83.14'	770.00'	47.45'	S12°25'58"E	47.44'	770.00'	83.18'	S6°14'00"E	83.14'	770.00'	83.28'	S0°02'24"E	83.24'	770.00'	83.18'	S6°14'00"E	83.14'	770.00'	47.45'	S12°25'58"E	47.44'	770.00'	83.18'	S6°14'00"E	83.14'	770.00'	83.28'	S0°02'24"E	83.24'	770.00'	83.18'	S6°14'00"E	83.14'	770.00'	47.45'	S12°25'58"E	47.44'	770.00'	83.18'	S6°14'00"E	83.14'	770.00'	83.28'	S0°02'24"E	83.24'	770.00'	83.18'	S6°14'00"E	83.14'	770.00'	47.45'	S12°25'58"E	47.44'	770.00'	83.18'	S6°14'00"E	83.14'	770.00'	83.28'	S0°02'24"E	83.24'	770.00'	83.18'	S6°14'00"E	83.14'	770.00'	47.45'	S12°25'58"E	47.44'	770.00'	83.18'	S6°14'00"E	83.14'	770.00'	83.28'	S0°02'24"E	83.24'	770.00'	83.18'	S6°14'00"E	83.14'	770.00'	47.45'	S12°25'58"E	47.44'	770.00'	83.18'	S6°14'00"E	83.14'	770.00'	83.28'	S0°02'24"E	83.24'	770.00'	83.18'	S6°14'00"E	83.14'	770.00'	47.45'	S12°25'58"E	47.44'	770.00'	83.18'	S6°14'00"E	83.14'	770.00'	83.28'	S0°02'24"E	83.24'	770.00'	83.18'	S6°14'00"E	83.14'	770.00'	47.45'	S12°25'58"E	47.44'	770.00'	83.18'	S6°14'00"E	83.14'	770.00'	83.28'	S0°02'24"E	83.24'	770.00'	83.18'	S6°14'00"E	83.14'	770.00'	47.45'	S12°25'58"E	47.44'	770.00'	83.18'	S6°14'00"E	83.14'	770.00'	83.28'	S0°02'24"E	83.24'	770.00'	83.18'	S6°14'00"E	83.14'	770.00'	47.45'	S12°25'58"E	47.44'	770.00'	83.18'	S6°14'00"E	83.14'	770.00'	83.28'	S0°02'24"E	83.24'	770.00'	83.18'	S6°14'00"E	83.14'	770.00'	47.45'	S12°25'58"E	47.44'	770.00'	83.18'	S6°14'00"E	83.14'	770.00'	83.28'	S0°02'24"E	83.24'	770.00'	83.18'	S6°14'00"E	83.14'	770.00'	47.45'	S12°25'58"E	47.44'	770.00'	83.18'	S6°14'00"E	83.14'	770.00'	83.28'	S0°02'24"E	83.24'	770.00'	83.18'	S6°14'00"E	83.14'	770.00'	47.45'	S12°25'58"E	47.44'	770.00'	83.18'	S6°14'00"E	83.14'	770.00'	83.28'	S0°02'24"E	83.24'	770.00'	83.18'	S6°14'00"E	83.14'	770.00'	47.45'	S12°25'58"E	47.44'	770.00'	83.18'	S6°14'00"E	83.14'	770.00'	83.28'	S0°02'24"E	83.24'	770.00'	83.18'	S6°14'00"E	83.14'	770.00'	47.45'	S12°25'58"E	47.44'	770.00'	83.18'	S6°14'00"E	83.14'	770.00'	83.28'	S0°02'24"E	83.24'	770.00'	83.18'	S6°14'00"E	83.14'	770.00'	47.45'	S12°25'58"E	47.44'	770.00'	83.18'	S6°14'00"E	83.14'	770.00'	83.28'	S0°02'24"E	83.24'	770.00'	83.18'	S6°14'00"E	83.14'	770.00'	47.45'	S12°25'58"E	47.44'	770.00'	83.18'	S6°14'00"E	83.14'	770.00'	83.28'	S0°02'24"E	83.24'	770.00'	83.18'	S6°14'00"E	83.14'	770.00'	47.45'	S12°25'58"E	47.44'	770.00'	83.18'	S6°14'00"E	83.14'	770.00'	83.28'	S0°02'24"E	83.24'	770.00'	83.18'	S6°14'00"E	83.14'	770.00'	47.45'	S12°25'58"E	47.44'	770.00'	83.18'	S6°14'00"E	83.14'	770.00'	83.28'	S0°02'24"E	83.24'	770.00'	83.18'	S6°14'00"E	83.14'	770.00'	47.45'	S12°25'58"E	47.44'	770.00'	83.18'	S6°14'00"E	83.14'	770.00'	83.28'	S0°02'24"E	83.24'	770.00'	83.18'	S6°14'00"E	83.14'	770.00'	47.45'	S12°25'58"E	47.44'	770.00'	83.18'	S6°14'00"E	83.14'	770.00'	83.28'	S0°02'24"E	83.24'	770.00'	83.18'	S6°14'00"E	83.14'	770.00'	47.45'	S12°25'58"E